

NOTES: UNLESS OTHERWISE SPECIFIED

1. ALL DIMENSIONS ARE IN INCHES.
2. DRAIN BODY MATERIAL: 14GA STAINLESS STEEL T304/T316
3. GRATING: PLAIN/SERRATED BAR GRATING, UPTO 'E' LOAD CLASS AVAILABLE.
4. SPECIFYING ENGINEER IS RESPONSIBLE FOR CONCRETE ENCASUREMENT AND REINFORCING BASED UPON APPLICATION AND LOCAL CODES.
5. REFER TO <https://info.slotdrainsystems.com/installresources> FOR INSTALLATION INSTRUCTIONS.

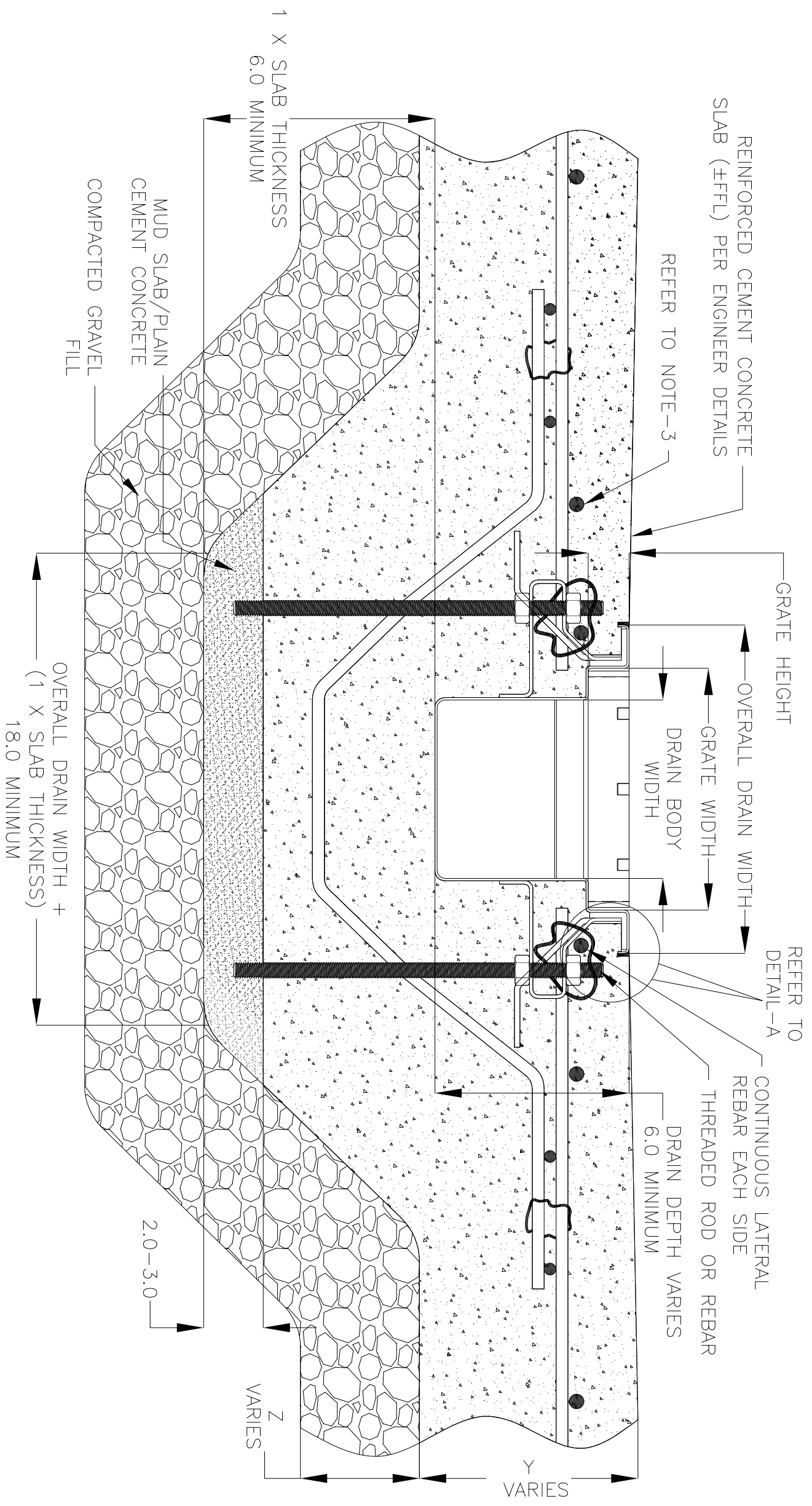

REINFORCED CEMENT CONCRETE SLAB (FFFL) PER ENGINEER DETAILS

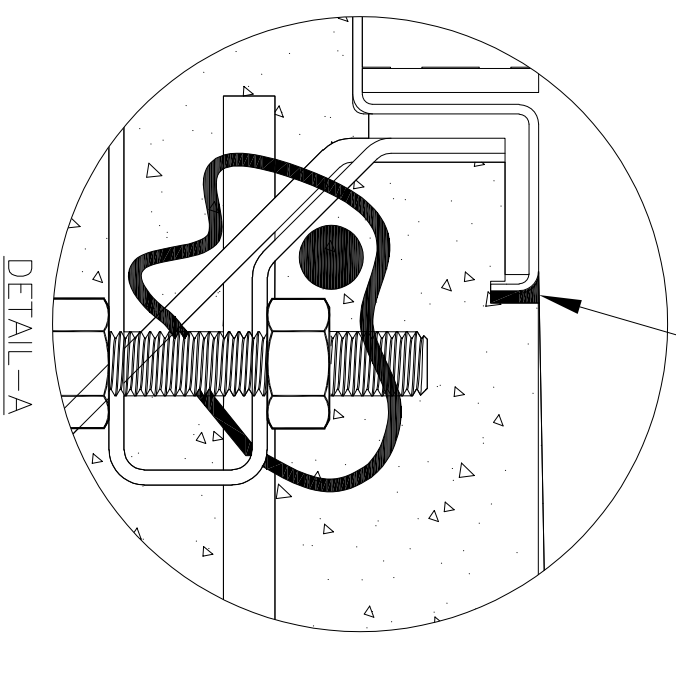
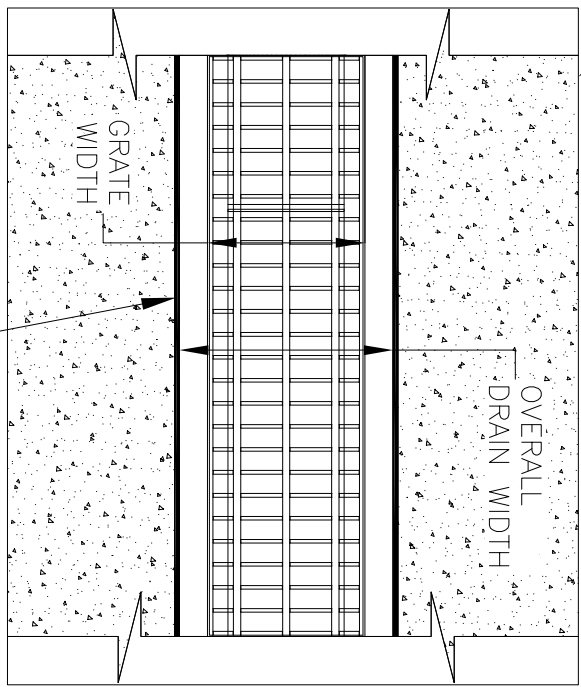

FOOD SAFE FLAT BOTTOM TRENCH DRAIN INSTALLATION DETAILS

REVISIONS		DATE	BY
REV	DESCRIPTION		
0	INITIAL RELEASE - R0	2/3/2020	DK
1	UPDATED DRAIN LAYOUT & REBAR DETAILS	9/14/2021	DK

**SLOT DRAIN**  
SYSTEMS

855.497.7508  
info@slotdrainsystems.com  
www.slotdrainsystems.com

DRAWING TITLE		CONCRETE FLOOR-NEW CONSTRUCTION INSTALLATION	
DRAIN SERIES		FOOD SAFE FLAT BOTTOM TRENCH DRAIN	
DWG NO.	SIZE	SCALE	SHEET
IN-FTF-002-R1	B	NTS	1 OF 1
REV.			1

ALL DRAWINGS ARE THE EXCLUSIVE PROPERTY OF SLOT DRAIN SYSTEMS. ANY REPRODUCTION IN PART OR IN WHOLE IS PROHIBITED WITHOUT PROPER CONSENT.